

Unedited Draft

Exploring the PowerShell Scripting Language

Windows PowerShell IN ACTION

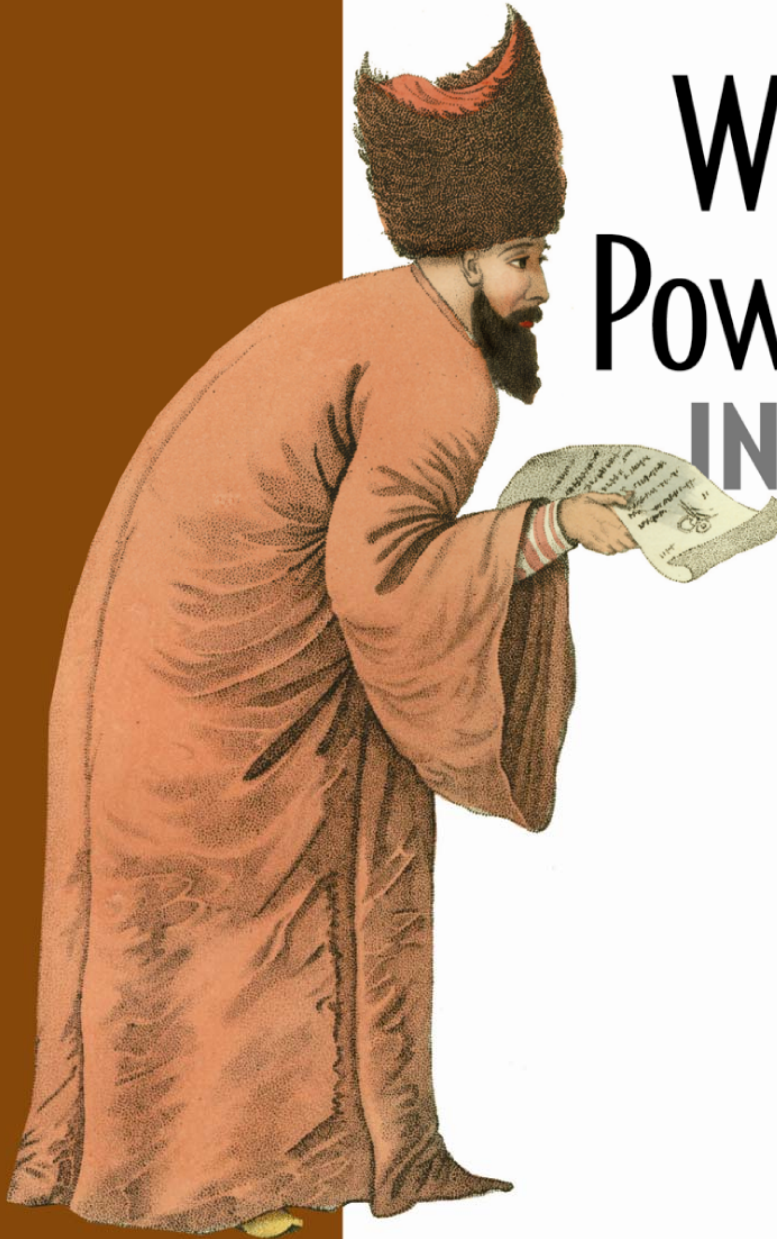

Bruce Payette

 MANNING



Windows PowerShell in Action
by Bruce Payette

Unedited Draft Chapter 1

Copyright 2006 Manning Publications

For more information on this and other Manning titles go to
www.manning.com

Chapter 1 – Welcome to PowerShell

“Space is big. Really big. You just won't believe how vastly hugely mindbogglingly big it is. I mean you may think it's a long way down the road to the chemist, but that's just peanuts compared to space”

“Don't Panic.”

Douglas Adams. The Hitchhiker's Guide to the Galaxy.

Welcome to Windows PowerShell – the new command and scripting language from Microsoft. We begin this chapter with two quotes from the Hitchhiker's Guide to the Galaxy. So what do they have to do with a new scripting language? Well – where a program solves a particular problem or problems, a programming language can solve *any* problem, at least in theory. That's the “big, really big” part. The “Don't Panic” bit is, well – don't panic. While PowerShell is new and different, it has been designed to leverage what you already know, making it easy to learn. It's also designed to allow you to learn it a bit at a time. Starting at the beginning, here's the traditional “Hello world.” program in PowerShell.

```
“Hello world.”
```

There – see - no panic needed. But “Hello world” by itself is not really very interesting. Here's something a bit more complicated:

```
dir $env:windir\*.log | select-string -List error |  
format-table path,linenumber -auto
```

Now – although this is a bit more complex, you can probably still figure out what it does. It searches all the log files in the Windows directory, looking for the string “error” then prints the full name of the matching file and the matching line number. “Useful but not very special,” you might think, because you can easily do this kind of thing using `cmd.exe` on Windows or `bash` on UNIX. So what about the “big, really big” thing? Well – how about this example?

```
([xml](new-object net.webclient).DownloadString(  
“http://blogs.msdn.com/powershell/rss.aspx”  
)).rss.channel.item| format-table title,link
```

Now we're getting somewhere. This little script does downloads the RSS feed from the PowerShell team weblog, and then display the title and link for each blog entry.

Note: RSS stands for Really Simple Syndication. This is a mechanism that allows programs to download Web logs automatically so they can be read more conveniently than in the browser.

By the way, you weren't really expected to figure this last example out yet. If you did – you move to the head of the class!

Finally – one last example:

```
[void][reflection.assembly]::LoadWithPartialName("System.Windows.Forms")
$form = new-object Windows.Forms.Form
$form.Text = "My First Form"
$button = new-object Windows.Forms.Button
$button.text="Push Me!"
$button.Dock="fill"
$button.add_click({$form.close()})
$form.controls.add($button)
$form.ShowDialog()
```

This script uses the Windows Forms framework (WinForms) to build a graphical user interface that has a single button. This button displays the text “Push Me”. When you push the button, it closes the form and exits the script. So there you go – from “Hello world” to a GUI application in less than two pages.

Now let’s come back down to earth for minute. The intent of Chapter 1 is to set the stage for understanding PowerShell – what it is, what it isn’t and – almost as important – why we made the decisions that we did in designing the PowerShell language. Chapter 1 covers the goals of the project along with some of the major issues we faced in trying to achieve those goals. By the end of the chapter you should have a solid base from which to start learning and using PowerShell to solve real-world problems. Of course all theory and no practice is boring, so the chapter concludes with a number of small examples to give you a feel for PowerShell. But first – a philosophical digression: while under development, the codename for this project was Monad. The name Monad comes from The Monadology by Gottfried Wilhelm Leibniz – one of the inventors of Calculus. Here is how Leibniz defined the Monad:

“The Monad, of which we shall here speak, is nothing but a simple substance, which enters into compounds. By 'simple' is meant 'without parts.'”
From THE MONADOLOGY by Gottfried Wilhelm Leibniz (translated by Robert Latta)

In the Monadology, Leibniz described a world of irreducible components from which all things could be composed. This excellently captures the spirit of the project – to create a toolkit of simple pieces that you compose to create complex solutions.

1.1 What is PowerShell?

So what is PowerShell and why was it created? As we said, PowerShell is the new command-line/scripting environment from Microsoft. The overall goal for this project was to *provide the best shell scripting environment possible for Microsoft Windows*. This statement has two parts and they are equally important – the goal was not just to produce a good generic shell environment but rather to produce one designed specifically for the Windows environment. While drawing heavily from existing command-line shell and scripting languages, the PowerShell language and runtime were designed from scratch to be an optimal environment for the modern Windows operating system.

Historically the Windows command line has been weak. This is mainly the result of the early focus in Microsoft on computing for the average user who is neither particularly technical nor particularly interested in computers. Most of the development effort for Windows was put into improving the graphical environment for the non-technical user rather creating an environment for the computer professional. Although this was certainly an enormously successful commercial strategy for Microsoft, it has left some segments of the community under-served.

In many ways, the PowerShell project brings Microsoft full circle. The first Microsoft product was a BASIC interpreter. You typed simple commands into the interpreter to control your computer. Through the

BASIC interpreter you had complete control over your computer. PowerShell gives you back this kind of control.

1.1.1 Shells, Command-Lines and Scripting Languages

In the last section, we called PowerShell a command line shell. So what is a shell? And how is that different from a command interpreter? What about scripting languages? If you can script in a shell language, doesn't that make it a scripting language? In answering these questions, let's start with shells.

Defining what a shell is can be a bit tricky; especially at Microsoft since pretty much everything at Microsoft has something called a shell. Windows Explorer is a shell. Even the Xbox has a shell. Historically the term *shell* describes the piece of software that sits over an operating system's core functionality. This core functionality is known as the operating system kernel. (Shell – Kernel – get it?) A shell is the piece of software that lets you access the functionality provided by the operating system. Windows Explorer is properly called a shell since it lets you access to the functionality of a Windows system. For our purposes though, we're more interested in the traditional text-based environment where the user types a command and gets a response. In other words, a shell is a command line interpreter. The two terms can be used pretty much interchangeably.

OK – so what is scripting and why are scripting languages not shells? To some extent, there isn't really a difference. Many scripting languages have a mode in which they take commands from the user and then execute those commands to return results. This mode of operation is called a Read-Evaluate-Print loop or *REP* loop. Not all scripting languages have these interactive loops but many do. In what way is a scripting language with a REP loop not a shell? The difference is mainly in the user experience. A proper command-line shell is also a proper user interface. As such, a command line has to provide a number of features to make the user's experience pleasant and customizable. The features that improve the user's experience include aliases (short-cuts for hard-to-type commands), wildcard matching so you don't have to type the full names for things and the ability to start other programs without having to do anything special like calling a function to do wildcard matching. Finally command line shells provide mechanisms for examining, editing and re-executing previously typed commands. These mechanisms are called command history.

If scripting languages can be shells, can shells be scripting languages? The answer is emphatically yes. With each generation, the UNIX shell languages have grown more and more powerful. It's entirely possible to write substantial applications in a modern shell language, such as bash or zsh. Scripting languages characteristically have an advantage over shell languages in that they provide mechanisms to help you develop larger scripts by letting you break a script into components or *modules*. Scripting languages typically provide more sophisticated features for debugging your scripts. Next scripting language runtimes are implemented in a way that makes their code execution more efficient, so that scripts written in these languages execute more quickly than they would in the corresponding shell script runtime. Finally scripting language syntax is oriented more towards writing an application than to interactively issuing commands.

In the end, there really is no hard and fast distinction between a shell language and a scripting language. Some of the features that make a good scripting language result in a poor shell user experience. Conversely, some of the features that make for a good interactive shell experience can interfere with scripting. Since PowerShell's goal is to be both a good scripting language and a good interactive shell, balancing the trade-offs between user-experience and scripting authoring was one of the major language design challenges.

1.1.2 Why a New Shell? Why Now?

In the early part of this decade, Microsoft commissioned a study to identify areas where it could improve its offerings in the server space. Server management and particularly command line management of Windows systems were called out as areas for improvement. While some might say that this is like discovering that water is wet, the important point is that people cared about the problem. When comparing the command line

manageability of a Windows system to a UNIX system, Windows was found to be limited and this was a genuine pain point with customers.

There are a number of reasons for the historically weak Windows command line. First, as mentioned previously, limited effort had been put into improving the command line. Since the average desktop user didn't care about the command line, obviously it wasn't considered important. Secondly, when writing graphical user interfaces, you need to access the things you're managing through programmer style interfaces called Application Programmer Interfaces (APIs). APIs are almost universally binary (especially on Windows), and binary interfaces are not command-line friendly.

Another factor is that as Windows acquired more and more subsystems and features, the number of things you had to think about when managing a system increased dramatically. To deal with this increase in complexity, the manageable elements were factored into structured data objects. This collection of management objects is known internally at Microsoft as the Windows management surface. While this factoring addressed overall complexity and worked well for graphical interfaces, it made things much harder to work with using a traditional text-based shell environment.

Finally, as the power of the PC increased, Windows began to move off the desktop and into the corporate data center. In the corporate data center, you have a large numbers of servers to manage and the graphical point and click management approach that worked well for a one machine doesn't scale. All these elements combined to make it clear that Microsoft could no longer ignore the command line.

1.1.3 The Last Mile Problem

But why do we care about command line management and automation? Because it helps to solve the Information Technology professional's version of last mile problem. The last mile problem is a classical problem that comes from the telecommunications industry. It goes like this: the telecom industry can effectively amortize its infrastructure costs across all its customers until it gets to the *last mile* where the service is finally run to an individual location. Installing service across this last mile can't be amortized because it serves only a single location. Also what's involved in servicing any particular location can vary significantly. Servicing a rural farmhouse is quite different and significantly more expensive than running service to a house on a city street.

In the Information Technology (IT) industry, the System Management last mile problem is figuring out how to manage each IT installation effectively and economically. Even a small IT environment has a wide variety of equipment and applications. One approach to solving this is through consulting – IT vendors provide consultants who build custom last mile solutions for each end-user. This, of course, has problems with recurring costs and scalability (it's great for the vendor though). A better solution for the end-user is to empower them to solve their own last mile problem. We do this by providing a toolkit to enable the end-user to build his own custom solutions. This toolkit can't merely be the same tools used to build the overall infrastructure – the level of detail required is too great. Instead you need a set of tools with a higher level of abstraction. This is where PowerShell comes in – its higher-level abstractions allow you to connect the various bits of your IT environment together more quickly and with less effort.

1.2 Soul of a New Language

The title of this section was adapted from Tracey Kidder's *Soul of a New Machine* – one of the best non-technical technical books ever written. Kidder's book described how Data General developed a new 32-bit minicomputer – the Eclipse - in a single year. At that time, 32-bit minicomputers were not just new computers; they represented a whole new class of computers. It was a bold, ambitious project; many considered it crazy. Likewise, the PowerShell project is not just about creating a new shell language. We are

developing a new class of object-based shell languages. And we've been told more than a few times that we were crazy.

In this section we're going to cover some of the technological forces that shaped the development of PowerShell. A unique set of customer requirements in tandem with the arrival of the new .NET wave of tools at Microsoft led to this revolution in shell languages.

1.2.1 Learning from History

In section 1.1.2 we described why Microsoft needed to improve the command line. Now let's talk about *how* we decided to improve it. In particular, let's talk about why we created a new language. This is certainly one of the most common questions people ask about PowerShell (right after "What - are you guys nuts?"). People ask "why not just use one of the UNIX shells?" or "why not extend the existing Windows command line?"

In practice, we did start with an existing shell language. We began with the shell grammar for the POSIX standard shell defined in IEEE Specification 1003.2. The POSIX shell is a very mature command line environment available on a huge variety of platforms including Microsoft Windows. It's based on a subset of the UNIX Korn Shell which is itself a superset of the original Bourne shell. Starting with the POSIX shell gave us a well specified and very stable base. Then we had to consider how to accommodate the differences that properly supporting the Windows environment would entail. We wanted to have a shell optimized for the Windows environment in the same way that the UNIX shells are optimized for this UNIX environment.

To begin with, traditional shells deal only with strings. Even numeric operations work by turning a string into a number, performing the operation and then turning it back into a string. Given that a core goal for PowerShell was to preserve the structure of the Windows data types, we couldn't simply use the POSIX shell language as is. This factor impacted the language design more than any other. Next we wanted to support a more conventional scripting experience where, for example, expressions could be used as you would normally use them in a scripting language like Perl or Python. With a more natural expression syntax, it would be much easier to work with the Windows management objects. Now we just had to decide how to make those objects available to the shell.

1.2.2 Leveraging .NET

One of the biggest challenges in developing any computer language is deciding how to represent data in that language. For PowerShell, the key decision was to leverage the .NET object model. .NET is a unifying object representation that is being used across all of the groups at Microsoft. It is a hugely ambitious project that has taken years to come to fruition. By having this common data model, all the components in Windows can share and understand each other's data.

One of .NET's most interesting features for PowerShell is that the .NET object model is *self-describing*. By this we mean that the object itself contains the information that describes the object's structure. This is important for an interactive environment – you need to be able to look at an object and see what you can do with it. For example, if PowerShell receives an event object from the system event log, the user can simply inspect the object to see that it has a data stamp indicating when the event was generated.

Traditional text-based shells facilitate inspection because everything is text. Text is great – what you see is what you get. Unfortunately, what you see is *all* you get. You can't pull off many interesting tricks with text until you turn it into something else. For example, if you want to find out the total size of a set of files, you can get a directory listing which looks something like the following:

```
02/26/2004  10:58 PM           45,452 Q810833.log
02/26/2004  10:59 PM           47,808 Q811493.log
02/26/2004  10:59 PM           48,256 Q811630.log
```

You can see where the file size is in this text but it isn't useful as is. You have to extract the sequence of characters starting at column 32 (or is it 33?) until column 39, remove the comma and then turn those characters into numbers. It would be much easier if you could just ask for the size of the files as a number in the first place. This is what .NET brings to PowerShell – self-describing data that can be easily inspected and manipulated without having to convert it to text until you really need to.

Choosing to use the .NET object model also brings an additional benefit – it allows PowerShell to directly use the extensive libraries that are part of the .NET framework. This brings to PowerShell a breadth of coverage rarely found in a new language.

1.2.3 *Brushing up on Objects*

"When I use a word," Humpty Dumpty said, in rather a scornful tone, "it means just what I choose it to mean—neither more nor less."

Lewis Carroll's "Through the Looking Glass"

Since the PowerShell environment uses objects in almost every thing it does, it's worth running through a quick refresher. If you're comfortable with object-oriented programming, feel free to skip most of this section, but do please read the section on objects and PowerShell.

There is no lack of "learned debate" (or bitter feuding) about what objects are and what object-oriented programming is all about. For our purposes, we'll use the simplest definition. An object is a package that contains both data and the information on how to use that data. Take a light bulb object as a simple example. This object would contain data describing its state - whether it's off or on. It would also contain the mechanisms or *methods* needed to change the on/off state. Non-object-oriented approaches to programming typically put the data in one place – say a table of numbers where 0 is off and 1 is on, and then provide a separate library of routines to change this state. To change its state, the programmer would have to tell these routines where the value representing a particular light bulb was. This could be complicated and is certainly error prone. With objects, because both the data and the methods are packaged in one place, much of complexity can be removed and many errors avoided.

1.2.4 *Reviewing Object Oriented Programming*

So that's what objects are. Now what is object-oriented programming? Well, it deals mainly with how you build these objects. Where do the data elements come from? Where do the behaviors come from? Most object systems determine the object's capabilities through its *type*. In the light bulb example, the type of the object is (surprise) `LightBulb`. It's the *type* of the object that determines what properties the object has, for example, `IsOn` and what methods it has, for example `TurnOn` and `TurnOff`.

Essentially an object's type is the blueprint or pattern for what an object looks like and how you use it. The type `LightBulb` would say that that it has one data element – `IsOn` and two methods `TurnOn()` and `TurnOff()`. Types are frequently further divided into two subsets:

- types that have an actual implementation of `TurnOn()` and `TurnOff()`. These are typically called *classes*
- types that only describe what the interfaces should look like but not how they work. These are called *interfaces*

The pattern `IsOn/TurnOn()/TurnOff()` could be an *interface* implemented by a variety of classes such as `LightBulb`, `KitchenSinkTap` or `Television`. All these objects have the same basic pattern for being turned on and off. From a programmer's perspective, if they all have the same *interface*, that is, the

same mechanism for being turned on and off, once you know how to turn one of these objects on or off, you can use any type of object that has that interface.

Types are typically arranged in hierarchies with the idea that they should reflect logical taxonomies of types. This taxonomy is made up of classes and subclass. An example taxonomy is shown in Figure 1.1.

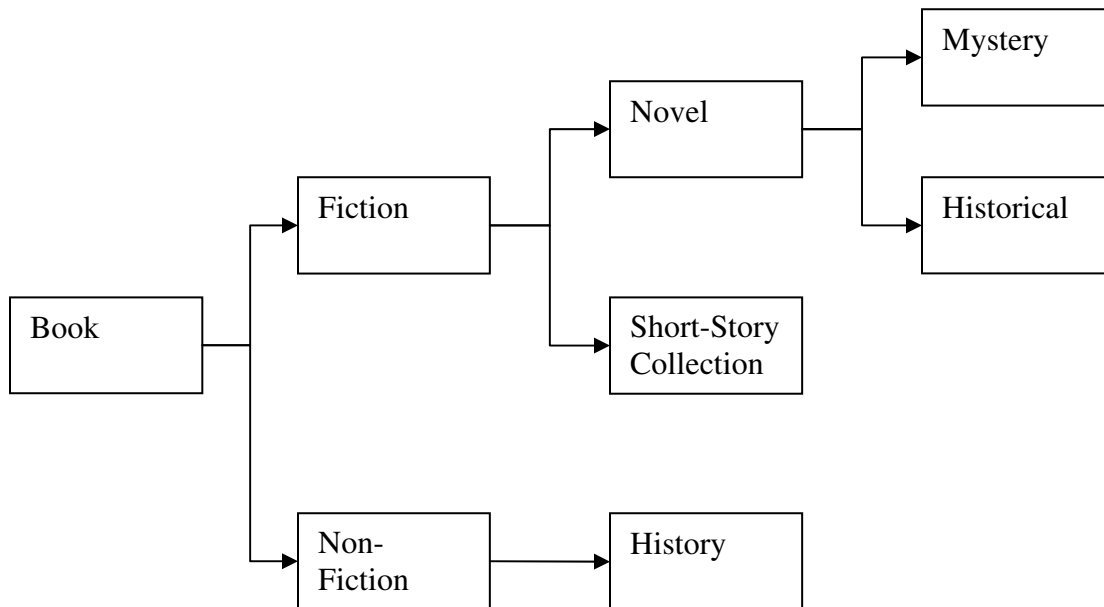

Figure 1.1 This diagram shows how books can be organized in a hierarchy of classes, just as object types can be organized into classes.

In this taxonomy, *Book* is the parent *class*; *Fiction* and *Non-fiction* are *subclasses* of *Book*, and so on. While taxonomies organize data effectively, designing a good taxonomy is hard. Frequently the best arrangement is not immediately obvious. In Figure 1.1, it might be better to organize by subject matter first, instead of the *Novel/Short-story Collection* grouping. In the scientific world, people spend entire careers categorizing things. Since it's hard to categorize well, people also arrange instances of objects into collections by containment instead of by type. A library contains books but it isn't itself a book. A library also contains other things that aren't books such as chairs and tables. If at some point you decide to re-categorize all of the books in a library, it doesn't affect what building people visit to get a book. It only changes how you find a book once you get to that building. On the other hand, if the library moves to a new location, you have to learn the new location. Once inside the building, however, your method for looking up books hasn't changed. This is usually called a *has-a* relationship – a library *has-a* bunch of books.

1.2.5 Objects in PowerShell

We've said that PowerShell is an *object-based* shell as opposed to an object-oriented language. What do we mean by object-based? In object-based scripting, you typically use objects somebody else has already defined for you. While it's certainly possible to build your own objects in PowerShell it isn't something that you usually need to worry about – at least not for most basic PowerShell tasks.

Going back to the `LightBulb` example, PowerShell would probably use the `LightBulb` class like this:

```
$lb = get-lightbulb -room bedroom  
$lb.TurnOff()
```

Don't worry about the details of the above syntax for now – we'll cover that later. The key point is that you usually get an object "foo" by saying

```
get-foo -option1 -option2 bar
```

rather than saying something like

```
new foo()
```

as you would in an object-oriented language.

PowerShell commands use verb-noun pairs. The `get-*` verb is used universally in the system to get at objects. Note that we didn't have to worry about whether `LightBulb` is a class or an interface, or care about where in the object hierarchy it comes from. You can get all of the information about the member properties of an object though the `get-member` command (see the pattern?) which will tell you all about an object's properties.

1.3 *Once Around Quickly*

But enough talk! By far the best way to understand PowerShell is to use it. In this section, we'll get you up and going with PowerShell and quickly tour through the basics of the environment. This is just a brief introduction intended to give you a taste of what PowerShell can do and how it works.

Note: The PowerShell documentation package also includes a short Getting Started guide which will include up-to-date installation information and instructions. You may want to take a look at this as well.

First things first – you'll almost certainly have to download and install the PowerShell package on your computer. Go to Microsoft downloads

<http://microsoft.com/downloads>

and search for "PowerShell". This will take you to the latest installer and any documentation packages or other materials available. Once you've located the installer, follow the instructions to install the package. After you have it installed, to start an interactive PowerShell session go to

```
Start -> Programs -> Windows PowerShell
```

When it's started, you'll see a screen like that shown in Figure 1.2.:

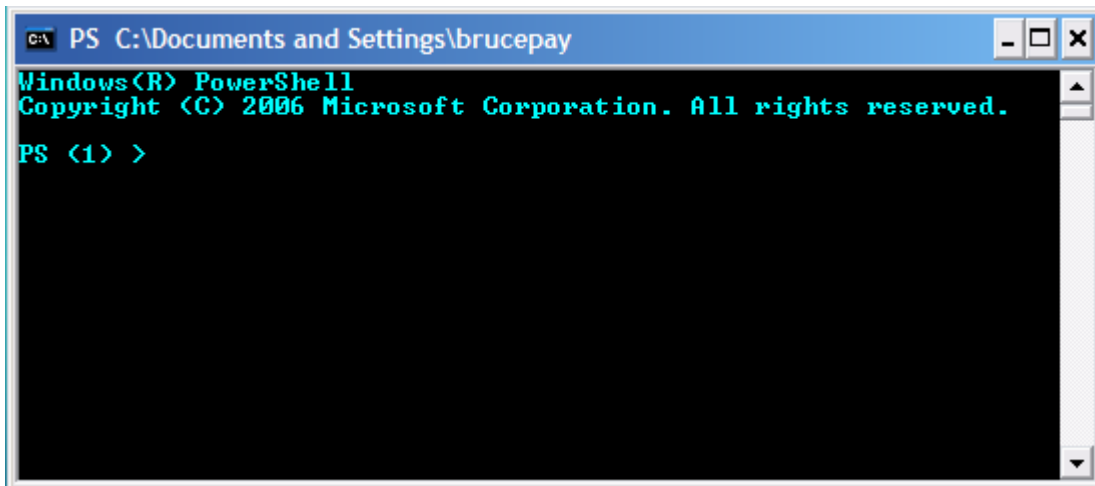

Figure 1.2 When you start an interactive PowerShell session, the PowerShell Prompt screen displays

Now type the first command most people type: “dir”. This produces a listing of the files on your system as shown in Figure 1.3.

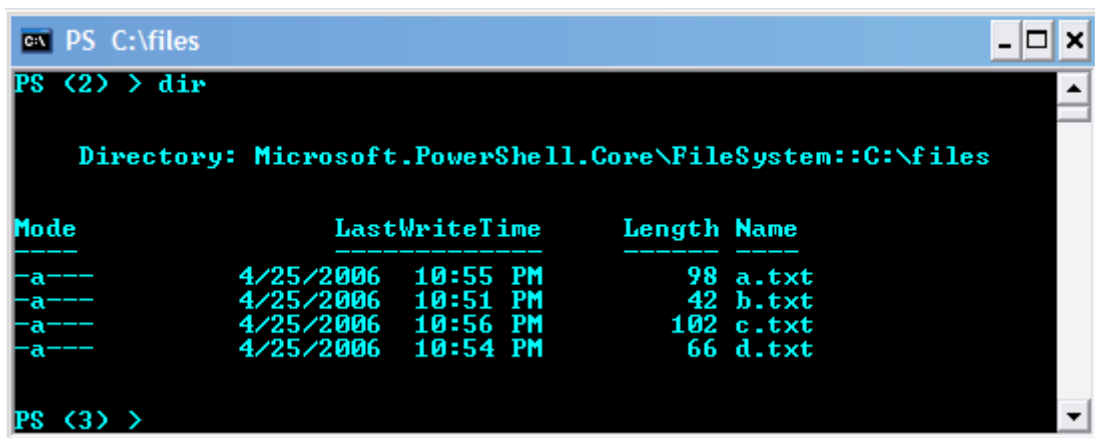

Figure 1.3 When you type the “dir” command, PowerShell displays a list of your files.

As you would expect, the `dir` command prints a listing of the current directory to standard output.

Let’s stop for a second and talk about the conventions we’re going to use in examples. Since PowerShell is an interactive environment, we’ll show a lot of example commands as the user would type them followed by the responses the system generates. Before the command text there will be a prompt string that looks like ‘PS (2) >’. Following the prompt, the actual command will be displayed in bold font. PowerShell’s responses will follow on the next few lines. Since PowerShell doesn’t display anything in front of the output lines, you can distinguish output from commands by looking for the prompt string. These conventions are illustrated in figure 1.4.

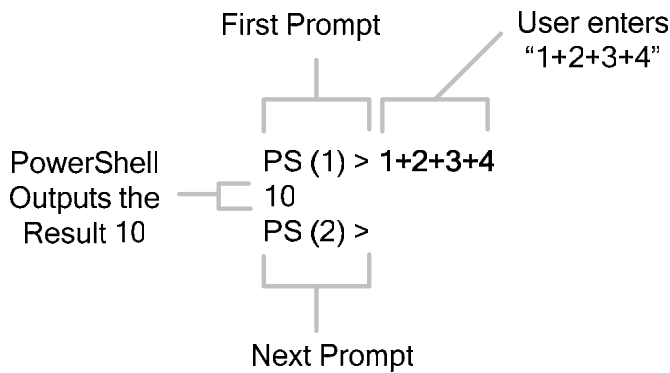

Figure 1.4 The conventions we’re using for examples in this book.

Now on to the examples. Instead of simply displaying the directory listing, let’s save it into a file using output redirection. In the following example, we redirect the output into the file `c:\foo.txt` and then use the `type` command to display what was saved:

```
PS (2) > dir c:\config.sys > c:\foo.txt
PS (3) > type c:\foo.txt

Directory: Microsoft.PowerShell.Core\FileSystem::C:\

Mode                LastWriteTime         Length Name
----                -
-a---             11/17/2004   3:32 AM             0 config.sys
PS (4) >
```

As you can see, commands work more or less as you’d expect if you’ve used other shells. Let’s go over some of the other things that should be familiar to you.

1.3.1 Command Editing

Command line editing works the same way for PowerShell as it does for `cmd.exe`. The available editing features and keystrokes are listed in Table 1.1.

Table 1.1 Command Editing Features

Keyboard Sequence	Editing Operation
Left/Right Arrows	Move the editing cursor left and right through the current command line.
Up/Down Arrows	Move up and down through the command history.
Insert Key	Toggles between character insert and character overwrite modes.
Delete Key	Deletes the character under the cursor
Backspace Key	Deletes the character behind the cursor.
F7	Pops up command history in a window on the console. Use the up and down arrows to select a command then enter to execute that command.

Keyboard Sequence	Editing Operation
Tab	Does command line completion. (See the next section for details)

These key sequences let you create and edit commands effectively at the command line. In fact they aren't really part of PowerShell at all. These command line editing features are part of the Windows console subsystem so they are the same across all console applications. There is one editing feature however that is significantly different for PowerShell. This is command completion, also call tab-completion. While `cmd.exe` does have tab-completion, PowerShell's implementation is significantly more powerful. We'll describe this feature next.

1.3.2 Command Completion

A very important feature at the command line is tab-completion. This allows you to partially enter a command then hit the tab key and have PowerShell try and fill in the rest of the command. By default PowerShell will do tab completion against the file system, so if you type a partial file name then hit tab, the system matches what you've typed against the files in the current directory and returns the first matching file name. Hitting tab again takes you to the next match and so on. PowerShell also supplies the powerful capability of tab-completion on wild cards (see Chapter 4 for information on PowerShell wild cards). This means that you can type:

```
PS (1) > cd c:\pro*files<tab>
```

and the command is expanded to:

```
PS (2) > cd 'C:\Program Files'
```

PowerShell will also do tab-completion on partial cmdlet names. If you enter a cmdlet name up to the dash then hit the tab key, the system will step through the matching cmdlet names.

So far this isn't much more interesting than what `cmd.exe` provide. What is significantly different is that PowerShell also does completion on parameter names. If you enter a command followed by a partial parameter name and hit tab, the system will step through all of the possible parameters for that command.

PowerShell also does tab-completion on variables. If you type a partial variable name then hit the tab key, PowerShell will complete the name of the variable.

And finally, PowerShell does completion on properties in variables. If you've used the Microsoft Visual Studio development environment, you've probably seen the Intellisense feature. Property completion is kind of a limited intellisense capability at the command line. If you type something like

```
PS (1) > $a="abcde"
PS (2) > $a.len<tab>
```

The system expands the property name to

```
PS (2) > $a.Length
```

Again, the first tab returns the first matching property or method. If the match is a method, an open parenthesis is displayed

```
PS (3) > $a.sub<tab>
```

Produces

```
PS (3) > $a.Substring(
```

Note that the system corrects the capitalization for the method or property name to match how it was actually defined. This doesn't really impact how things work. PowerShell is case-insensitive by default whenever it has to match against something. (There are operators that allow you to do case-sensitive matching, which are discussed in Chapter 3).

1.3.3 Basic Expressions

As well as running commands, PowerShell can also evaluate expressions. In effect, it operates as a kind of calculator. Let's evaluate a simple expression:

```
PS (4) > 2+2  
4
```

Notice that as soon as you typed the expression, the result was calculated and displayed. It wasn't necessary to use any kind of print statement to display the expression. This is fairly important to remember – when an expression is evaluated, the result of the expression is output, not discarded. We'll explore the implications of this in later sections.

Here are few more examples of PowerShell expressions examples:

```
PS (5) > (2+2)*3  
12  
PS (6) > (2+2)*6/2  
12  
PS (7) > 22/7  
3.14285714285714
```

You can see from these examples that PowerShell supports most of the basic arithmetic operations you'd expect including floating point.

PowerShell supports single and double precision floating point as well as the .NET decimal type. See Chapter 3 for more details.

Since we've already shown how to save the output of a command into a file using the redirection operator, let's do the same thing with expressions:

```
PS (8) > (2+2)*3/7  
1.71428571428571  
PS (9) > (2+2)*3/7 > c:\foo.txt  
PS (10) > type c:\foo.txt  
1.71428571428571
```

Saving expressions into files is useful; saving them in variables is more useful:

```
PS (11) > $n = (2+2)*3
PS (12) > $n
12
PS (13) > $n / 7
1.71428571428571
```

Variables can also be used to store the output of commands:

```
PS (14) > $files = dir
PS (15) > $files[1]
```

```
Directory: Microsoft.PowerShell.Core\FileSystem::C:\Documents
 and Settings\brucepay
```

Mode	LastWriteTime	Length	Name
d----	4/25/2006 10:32 PM		Desktop

In this example, we extracted the second element of the collection of file information objects returned by the `dir` command.

(Note that collections in PowerShell start at 0 not at 1 – this is a characteristic we’re inherited from the .NET Common Language Runtime specification. This is why `$files[1]` is actually extracting the *second* element, not the first.)

1.3.4 Processing Data

As you’ve seen in the preceding sections, you can run commands to get information and store it in files and variables. Now let’s do some processing on that data. First let’s sort a list of files. Here’s the initial list. By default it’s sorted by name.

```
PS (16) > cd c:\files
PS (17) > dir
```

```
Directory: Microsoft.PowerShell.Core\FileSystem::C:\files
```

Mode	LastWriteTime	Length	Name
-a---	4/25/2006 10:55 PM	98	a.txt
-a---	4/25/2006 10:51 PM	42	b.txt
-a---	4/25/2006 10:56 PM	102	c.txt
-a---	4/25/2006 10:54 PM	66	d.txt

Now – let’s run it through the sort utility:

```
PS (18) > dir | sort
```

```
Directory: Microsoft.PowerShell.Core\FileSystem::C:\files
```

Mode	LastWriteTime	Length	Name
-a---	4/25/2006 10:55 PM	98	a.txt
-a---	4/25/2006 10:51 PM	42	b.txt

```
-a---          4/25/2006  10:56 PM          102 c.txt
-a---          4/25/2006  10:54 PM           66 d.txt
```

OK – it’s not very interesting – sorting an already sorted list gives you the same thing. Let’s do something a bit more interesting. Let’s sort by name in descending order:

```
PS (19) > dir | sort -descending
```

```
Directory: Microsoft.PowerShell.Core\FileSystem::C:\files
```

Mode	LastWriteTime	Length	Name
-a---	4/25/2006 10:54 PM	66	d.txt
-a---	4/25/2006 10:56 PM	102	c.txt
-a---	4/25/2006 10:51 PM	42	b.txt
-a---	4/25/2006 10:55 PM	98	a.txt

So there you have it—files sorted by name in reverse order. Now let’s sort by something other than the name of the file. For example, let’s sort by file length. You may remember from an earlier section how hard it would be to sort by file length if the output were just text.

In fact, on a UNIX system, this sort command looks like:

```
ls -l | sort -n -k 5
```

which is pretty opaque. Here’s what it’s doing. The `-n` option tells the `sort` function that you want to do a numeric sort. `-k` tells you which field you want to sort on. In the output of the `ls -l` command, the field containing the length of the file is at offset 5. You need to set things up this way because `ls` produces unstructured strings. You have to tell `sort` how to parse those strings before it can sort them. In PowerShell, you don’t have to tell it to sort numerically – it already knows the type of the field and you can specify the field by name instead of providing a numeric offset.

In PowerShell, it’s trivial to sort by a particular field, we must merely provide the field name, and the system does the rest.

```
PS (20) > dir | sort -property length
```

```
Directory: Microsoft.PowerShell.Core\FileSystem::C:\files
```

Mode	LastWriteTime	Length	Name
-a---	4/25/2006 10:51 PM	42	b.txt
-a---	4/25/2006 10:54 PM	66	d.txt
-a---	4/25/2006 10:55 PM	98	a.txt
-a---	4/25/2006 10:56 PM	102	c.txt

In this example, we’re working with the output as objects, that is, things having a set of distinct characteristics accessible by name.

In the meantime, let’s introduce a new cmdlet – `select-object`. This cmdlet allows you to select either subsets of the objects or subsets of the properties returned by a command. Say we want to get the largest file in a directory and put it into a variable:

```
PS (21) > $a = dir | sort -property length -descending |
```

```
>> select-object -first 1
>>
PS (22) > $a
```

```
Directory: Microsoft.PowerShell.Core\FileSystem::C:\files
```

Mode	LastWriteTime	Length	Name
----	-----	-----	----
-a---	4/25/2006 10:56 PM	102	c.txt

From this we can see that the largest file is c.txt.

Note, by the way, the secondary prompt “>>” in the previous example. The first line of the command ended in a pipe symbol. The PowerShell interpreter noticed this, saw that the command was incomplete and prompted for additional text to complete the command. Once the command is complete, you type a second blank line to send the command to the interpreter.

Now say we want only the name of the directory containing the file and not all of the other properties of the object. We can also do this with `select-object`. As with the `sort` cmdlet, `select-object` also takes a `-property` parameter (you’ll see this frequently in the PowerShell environment – commands are very consistent in their use of parameters.)

```
PS (23) > $a = dir | sort -property length -descending |
>> select-object -first 1 -property directory
>>
PS (24) > $a
```

```
Directory
-----
C:\files
```

So – we now have an object with a single property. The final simplification is to get just the value itself. Let’s introduce a new cmdlet that let’s you do arbitrary processing on each object in a pipeline. The `foreach-object` cmdlet executes a block of statements for each object in the pipeline.

```
PS (25) > $a = dir | sort -property length -descending |
>> select-object -first 1 |
>> foreach-object { $_.DirectoryName }
>>
PS (26) > $a
C:\files
```

This shows that we can get an arbitrary property out of an object then do arbitrary processing on that information using the `foreach-object` command. Combining those features, here’s an example that adds up the lengths of all of the objects in a directory.

```
PS (27) > $total = 0
PS (28) > dir | foreach-object {$total += $_.length }
PS (29) > $total
308
```

In this example, we initialize the variable `$total` to 0, then add to it the length of each file returned by the `dir` command and finally display the total.

Finally PowerShell has the usual script flow control statements like `while` loops and `if` statements:

```
PS (1) > $i=0
PS (2) > while ($i++ -lt 10) { if ($i % 2) {"$i is odd"}}
1 is odd
3 is odd
5 is odd
7 is odd
9 is odd
PS (3) >
```

Here we're using the `while` loop to count from 0 through 9. In the body of the `while` loop, we have an `if` statement that tests to see if the current number is odd and then writes out a message if it is. There are a number of additional flow control statements. The complete set of these features is covered in Chapter 6.

This is the end of our "Cook's tour" of PowerShell and we've only breezed over the features and capabilities of the environment. In the subsequent chapters we'll cover each of the elements discussed here in detail and a whole lot more.

1.4 Summary

This chapter covered what PowerShell is and, just as important, why it is. We also took a whirlwind tour through some simple examples of using PowerShell interactively. Here are the key points that were covered:

- PowerShell is the new command-line and scripting environment from Microsoft Corporation.
- The Microsoft Windows management model is primarily object-based which required us to take a novel approach to command-line scripting.
- PowerShell uses the .NET object model as the base for its type system.
- We're not crazy. Really! We've written papers and everything!

In the next chapter we'll look at each of the language features we showed you in much more detail.